



Aladdin

**BLUE FLAME
HEATER**

■
**THE FLAME
MUST BE BLUE**

■
**USE ONLY
KEROSENE
(PARAFFIN)**

■
**DO NOT
BURN DRY**

■
**KEEP THE
HEATER CLEAN**

■
**READ THESE
INSTRUCTIONS**

■

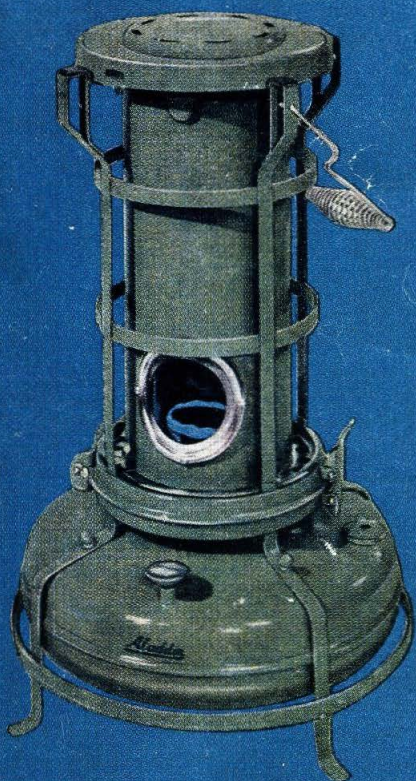

**OPERATING
INSTRUCTIONS**

INSTRUCTIONS for operating the

You have just purchased one of the world's finest heaters. It is manufactured in accordance with British Standard 3300:1960, the highest heating appliance standard in the world. Used in the right way it will be absolutely safe and odourless, but, even if you have used an oil heater before, please READ these instructions before you light it.

FIG.
1

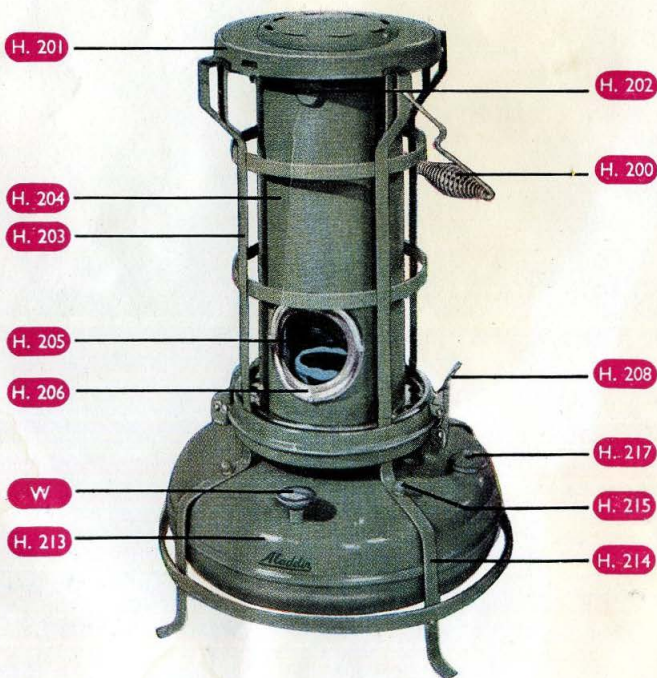

ALADDIN BLUE FLAME HEATER

Before using the heater you should remove all cardboard packing pieces, etc. which have been used to protect the heater during transit. Release spring clip (H.208) so that the whole of the top of the heater can be lowered to expose the burner. Remove the packing. Close the top of the heater and make sure that the spring clip engages fully with the catch before carrying.



UNPACKING

Unscrew filler cap (H.216) which will be found on the top of the tank (H.213) exactly opposite the wick winder 'W' and fill the tank, which will hold one gallon (4.5 litres), with best quality kerosine (paraffin). We recommend ALADDIN PINK PARAFFIN (available in U.K. and Eire). Don't use vaporising oil or *power* kerosine. NEVER USE motor fuel (Gasolene, Benzine, Essence, etc.) or other dangerous fuels. Replace filler cap and wipe the top of the tank clean. When lighting for the first time, or when a new wick (H.210) has been fitted, leave the heater unlit for an hour so that the wick can become thoroughly soaked. This heater will run for at least 16 hours on a filling. Do not burn the heater dry. The oil gauge (H.217) will show when the tank is approximately (a) full, (b) $\frac{3}{4}$ full, (c) $\frac{1}{2}$ full, (d) $\frac{1}{4}$ full, (e) empty (see fig. 2).



**TO
FILL**

**FIG.
2**



TO LIGHT

(Fig. 3)

Release spring clip and lower top of heater. Make sure flame spreader (H.212) is in position the correct way up and pushed fully home. Turn wick winder 'W' clockwise until about $\frac{1}{8}$ inch of wick is visible above the burner basket flange 'A' and light wick. Close top of heater and make sure that the spring clip is properly fastened. The flame can now be adjusted, within the limits of the burner, to give the heat required.

At no time should force be used on the wick winder. If difficulty is experienced in raising the wick the burner basket (H.209) should be removed and the trouble corrected. (See "To fit new wick"). The colour of the flame will tell you when it is set within the safe limits of the burner and it should ALWAYS be

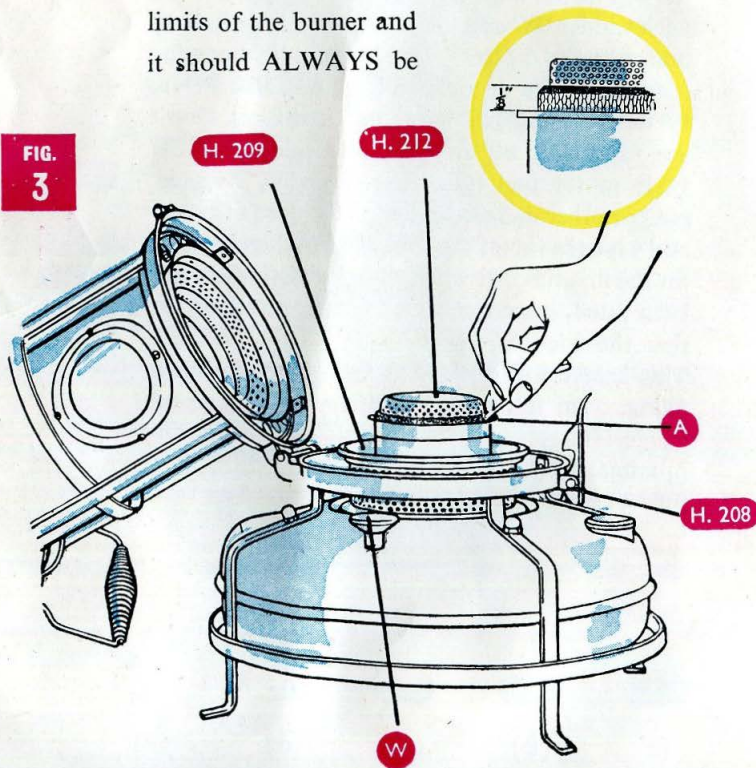

FIG.
3



FIG.
4

RIGHT

COMPLETELY BLUE as in fig. 4 (slightly reddish glow above flame proper is normal and intermittent red flecks may appear in dusty atmosphere). If it is too low it will be wholly or partly yellow as in fig. 5. If it is too high distinct yellow spikes will develop as in fig. 6. Operating the burner within these limits is of the utmost importance since, although there is no immediate danger, the presence of yellow flame means that the heater is not being used correctly and smoking or overheating of the burner may result. When using the heater for the first time turn the wick right up and right down a few times and compare the flame with the illustrations until you can immediately recognise a good or bad flame. If maximum heat is required it will be found convenient to turn the wick up until the yellow spikes appear and then turn it down again until a completely blue flame is obtained. Once the heater has been set with a completely blue flame it can be left with absolute confidence without any attention whatever until refilling is required, provided that reasonable ventilation is allowed. If it is impossible to obtain a completely blue flame either (a) the wick needs cleaning or replacing or (b) some part of the burner has been left off or incorrectly replaced or (c) some part of the burner is damaged or (d) inferior or dirty oil has been used.



FIG.
5

WRONG



FIG.
6

WRONG

TO EXTINGUISH

Turn wick down, lower top of heater and blow out. Turn wick up again and make sure it is out.

FIG.
7

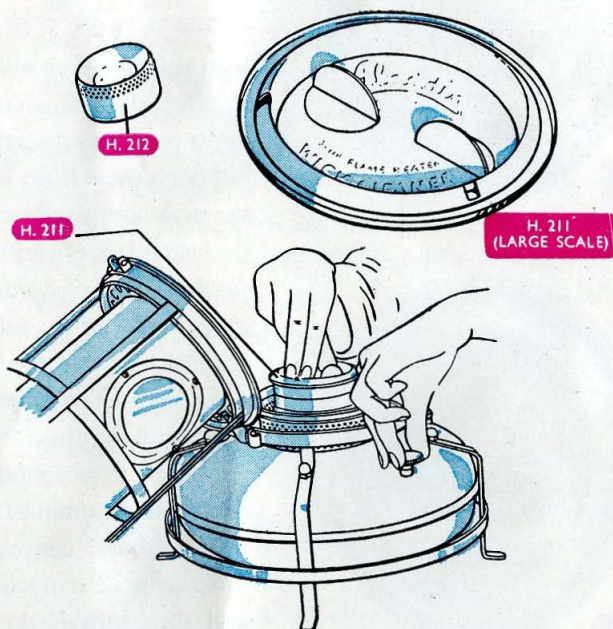

TO CLEAN WICK

(Fig. 7)

The frequency of wick cleaning will vary with the quality of oil and the height of flame used. Cleaning is necessary whenever the flame deteriorates and at least once a week when the heater is used continuously. Lower top of heater and remove flame spreader. Turn wick down below the burner basket flange. Place the wick cleaner (H.211) on the burner in place of the flame spreader where it will rest on the burner basket flange. With one hand turn the wick cleaner in a clockwise direction **KEEPING IT PRESSED DOWN ON TO THE BURNER BASKET FLANGE** and with the other hand turn the wick up slowly. As soon as the wick touches the

cleaner, black carbon will appear through the gaps. Continue turning the cleaner and turning the wick up GENTLY until no more carbon comes through the gaps and, provided the cleaner has been kept pressed on to the burner basket flange, a perfectly cleaned and shaped wick will result. Turn wick down and remove cleaner. Take out burner basket by turning anti-clockwise and lifting. Clean burner basket with a cloth, particularly the flange at the top. When replacing make sure it is correctly in position. Always clean wick with the wick cleaner provided NEVER USE SCISSORS, RAZOR BLADES, ETC.

Having cleaned the wick, check that there is no fluff or dirt in the burner basket, the flame spreader, or in the gap at the bottom of the chimney. Clean these parts when necessary; if the holes become blocked the burner may not function properly. As with all oil burners it must be kept CLEAN. The flame spreader and burner basket are rustproof and may be washed in warm soapy water, both being removed for this purpose. Neither the wick nor the tank must be washed with water; the tank may be rinsed out occasionally with CLEAN kerosine (paraffin). On no account should any parts of the heater be stood on a hot stove to dry.



**TO CLEAN
BURNER**

This is only necessary if the wick has become very uneven due to partial starvation resulting from a badly fitted wick (see "To fit new wick") or incorrect or infrequent wick cleaning. Empty tank as far as possible. Lower top of heater and adjust wick so that the LOWEST part of the burning edge is level with the burner basket flange. Light the wick, close the top of the heater and allow it to burn dry. Do not blow it out. The wick must now be reshaped exactly as in cleaning. After this operation the tank must be filled and the wick allowed to soak for an hour before lighting. An unpleasant smell may be given off during re-charring.



**TO
RE-CHAR
WICK**

FIG.
8

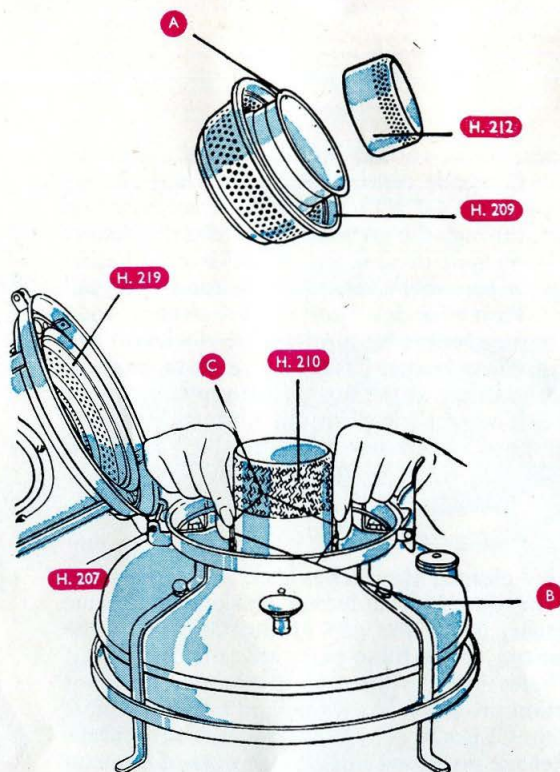

When the wick cannot be raised any further **WITHOUT USING FORCE** the wick needs replacing. The wick is not intended to burn down to the yellow band which is used to maintain the shape of the wick only. If force is exerted on the wick winder it is liable to damage the mechanism.

To avoid handling a wick fully soaked with kerosine (paraffin) it is better, though not essential, to allow the heater to burn dry, but as the wick itself will burn it is not advisable to leave the heater in a room where this odour would be unpleasant. By allowing the heater to burn dry on normal flame the wick will be damaged, but since in this case it is to be thrown away it will not matter.

Lower top of heater and remove flame spreader and burner basket. Raise the wick to its fullest extent. Detach the two wick carrier arms 'C', which

TO FIT NEW WICK

(Fig. 8)

will now be visible, from the brass studs on the wick by springing them outwards and then pulling one towards you and pushing the other away from you and remove old wick. Replace the flame spreader. This will avoid the yellow tape on the inside of the wick catching on the top of the wick tube. Fit the new wick over the inner wick tube so that when lowered the brass studs 'B' will engage with the wick carrier arms. Handling the wick well down to avoid damaging the charred top surface, ease gently down until the brass studs are level with the wick carrier arms. Make sure that both tails reach the bottom of the tank; this necessitates pushing one of the tails through the stirrup-like carrier arms. Failure to do so will cause that side of the wick to be starved resulting in a poor flame and very uneven burning of the wick. Engage the wick carrier arms with the brass studs 'B' on the wick and replace the burner basket. Allow the wick to soak for an hour before lighting.

Remove the top cover (H.201) by turning anti-clockwise and lifting.

This heater is constructed with a "floating" gallery (H.219) and chimney assembly which allows free movement in the frame. This movement must not be mistaken for a defect and no attempt should be made to secure the gallery or to interfere with its free movement in any way.



**FOR
COOKING**



**IMPORTANT
NOTE**

REMEMBER THESE VITAL POINTS



1. Make sure all parts are undamaged and in their correct position.
2. NEVER burn the heater with any yellow flame. IT MUST BE BLUE.
3. Clean wick regularly and with WICK CLEANER only.
4. Keep the heater CLEAN. Pay particular attention to the burner, since if the air holes or passages become even partially blocked the burner will not operate properly.
5. Use a first grade kerosine (paraffin). We recommend **ALADDIN PINK** (available in U.K. and Eire). NEVER USE motor fuel (Gasolene, Benzine, Essence, etc.) or other dangerous fuels.
6. **IMPORTANT. WHEN USING THIS, OR ANY OTHER Kerosine (PARAFFIN) OPERATED APPLIANCE, ALWAYS ENSURE THAT THE ROOM IS REASONABLY VENTILATED.**
7. Do not dry clothes or anything else over or near the heater.
8. WE CANNOT ACCEPT ANY RESPONSIBILITY FOR THE PERFORMANCE OR RELIABILITY OF ANY OF OUR APPLIANCES UNLESS **GENUINE ALADDIN SPARE PARTS ARE USED.** Use of reference numbers will enable your stockist to provide the correct part.
9. NEVER add salt, vinegar, camphor or any other substance to the kerosine (paraffin). It will not improve the kerosine (paraffin) or the performance and may well damage the heater beyond repair.
10. Do not fill the heater when it is alight. Fill tank regularly and never let it burn dry.
11. Never carry the heater whilst it is alight.
12. Never use the heater in a draught.
13. Never place the heater where it can be knocked over.

SPECIFICATIONS

Heat output	B.Th.Us. per hr.	5,870-9,320
	Kilogram Calories per hr.	1,470-2,330
Equivalent to		1 $\frac{3}{4}$ -2 $\frac{3}{4}$ kilowatts
Consumption		25-16 hrs. per gallon
Approximate capacity		1 gallon (4.5 litres)

SPARE PARTS

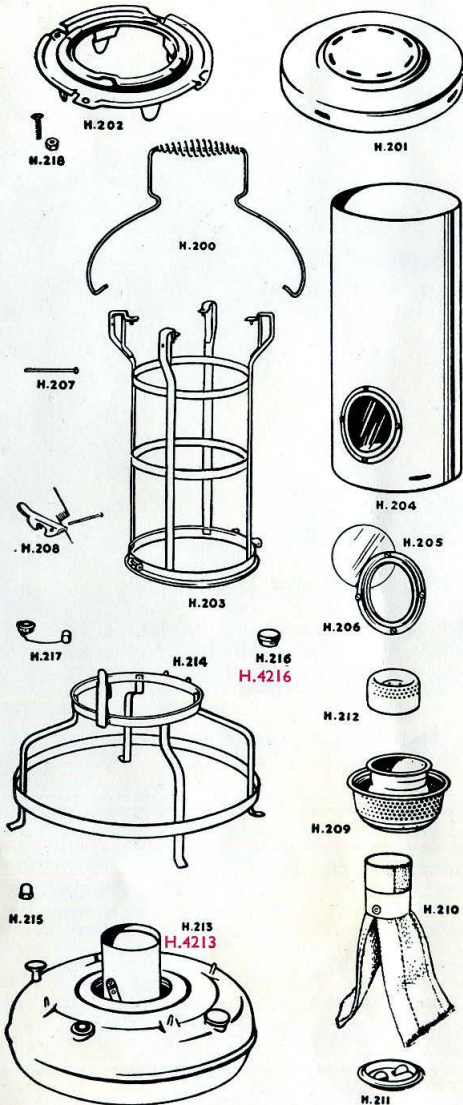

- H.200 B.F.H. Handle
- H.201 " Top cover
- H.202 " Boiling ring
- H.218 " Boiling ring nuts & bolts (set of four)
- *H.241 " Top frame protector
- H.203 " Top frame
- H.204 " Chimney
- *H.219 " Gallery with chimney clips, etc.
- *H.220 " Chimney clips, etc. (3)
- H.205 " Mica
- H.206 " Frame and screws for mica
- H.207 " Hinge pin
- H.208 " Spring clip assembly
- H.209 " Burner basket
- H.210 " Wick
- H.211 " Wick cleaner
- H.212 " Flame spreader
- H.213 " Tank complete
- H.4213** " " "
- H.214 " Bottom frame
- H.215 " Dome nut
- H.216 " Filler cap and washer
- H.4216** " **Filler cap and washer**
- H.217 " Oil gauge

*Not illustrated

Where Export Parts differ from those supplied in U.K. and Eire they are shown above in red. The red numbers should always be quoted where Export Parts are required.



*These devices are the registered Trade Marks
of Aladdin Industries Limited in Great Britain*



Aladdin^{*}

** Registered Trade Mark * Marca Registrada*

Owned by Aladdin Industries Limited, Greenford, England, or in certain countries by Licensors: Aladdin Industries Inc., Nashville, Tennessee, U.S.A., or Industries Aladdin, S.A., Paris, France, or Aladdin Industries Pty. Limited, Sydney, Australia.

Information on request from Patent Department, Aladdin Industries Limited, Greenford, England.

"ALADDIN" and "PINK" are joint Registered Trade Marks of Aladdin Industries Limited and Shell Mex and B.P. Limited in respect of paraffin in U.K. and Eire.

ALADDIN INDUSTRIES LIMITED
GREENFORD **ENGLAND**